

To ensure proper assembly of your **Kite**® folding table, please take time to read through the steps in this **assembly guide** and follow them carefully. We have already attached the table frame to the table top for you.

1

Remove the table from the box.
For ease of assembly and to avoid injury, ensure the table is lifted by two people.

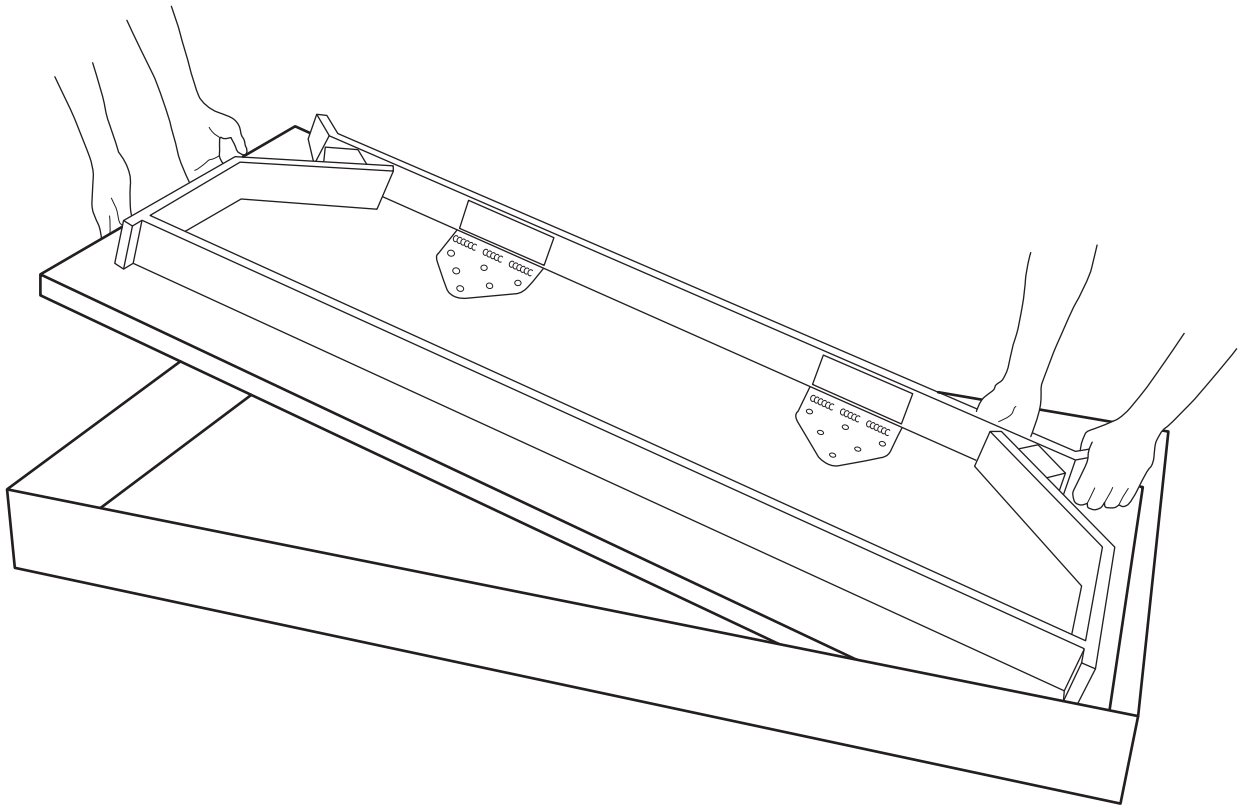

2

Place the table face down on a soft, clean surface to eliminate the possibility of scratching.

Note: Once the first table has been assembled, it can be used as a bench to assemble further tables. We recommend using the rectangle shape as a bench, with the box lid placed on top to avoid scratching.

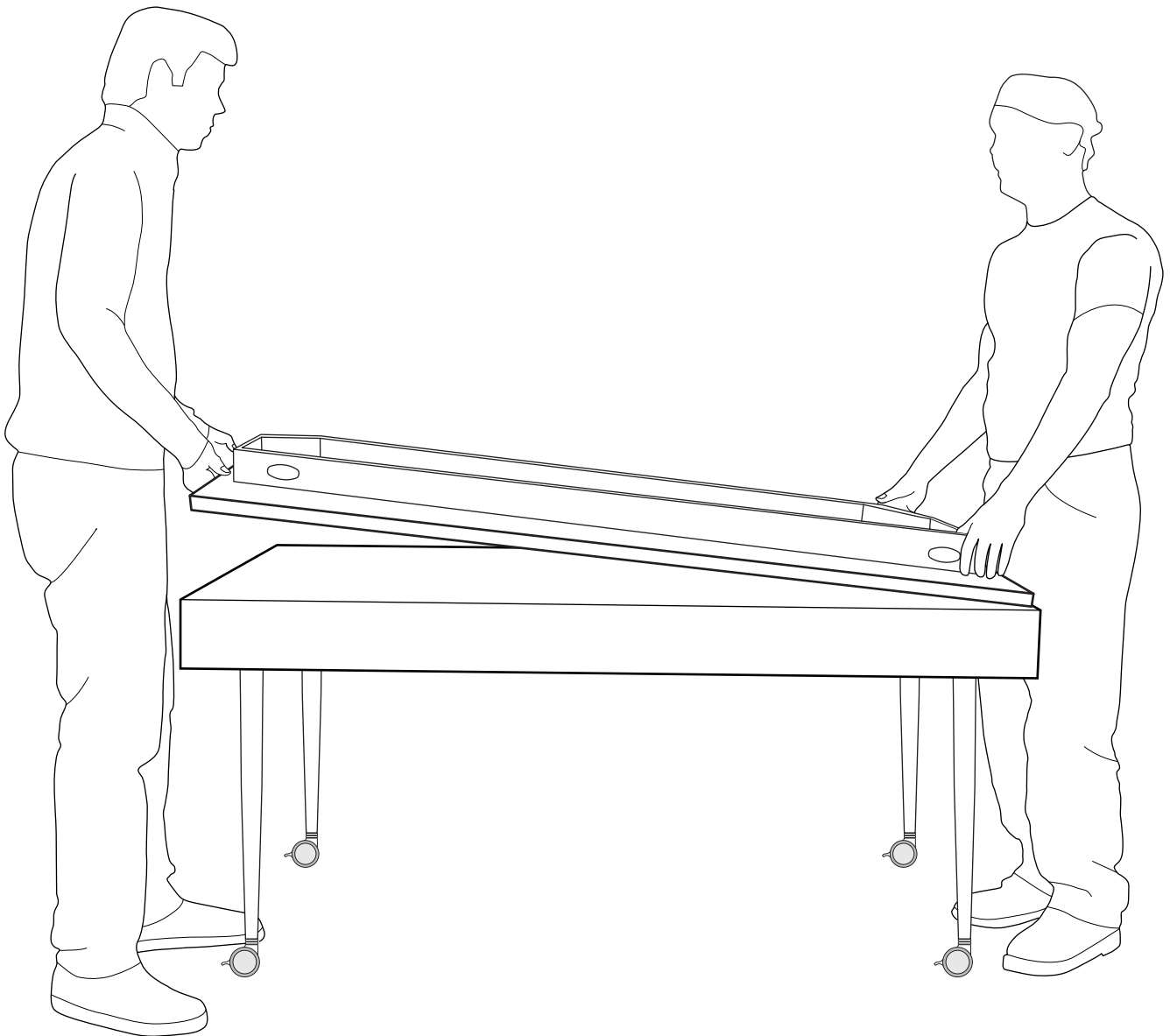

3

Remove a leg from the box. Insert the leg bolts through the two holes as shown, until the thread is showing on the other side.

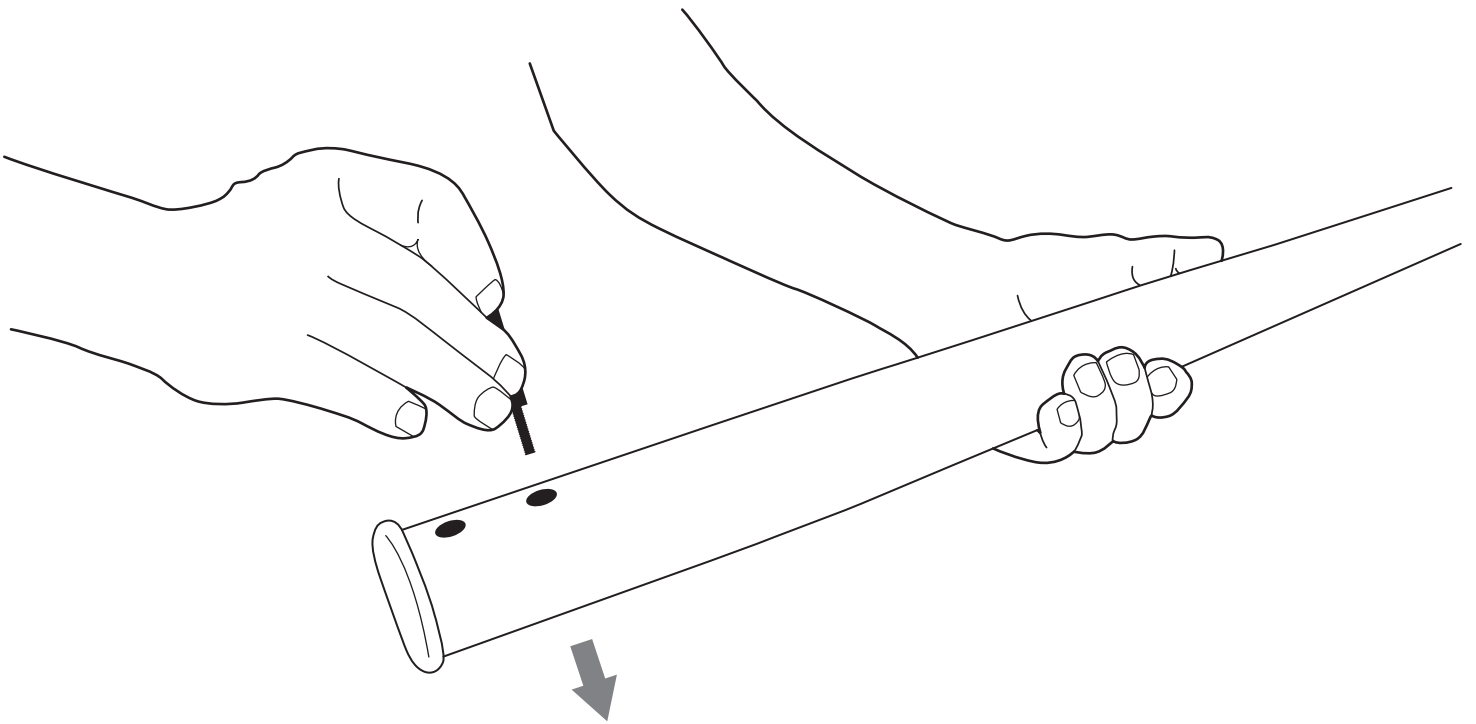

4

Screw the leg bolts to the Kite frame by hand.
Tighten with the allen key provided. Repeat steps 3 and 4 until all the legs are securely fastened to the frame.

Note: Extra care should be taken to avoid double crossing the bolt thread.

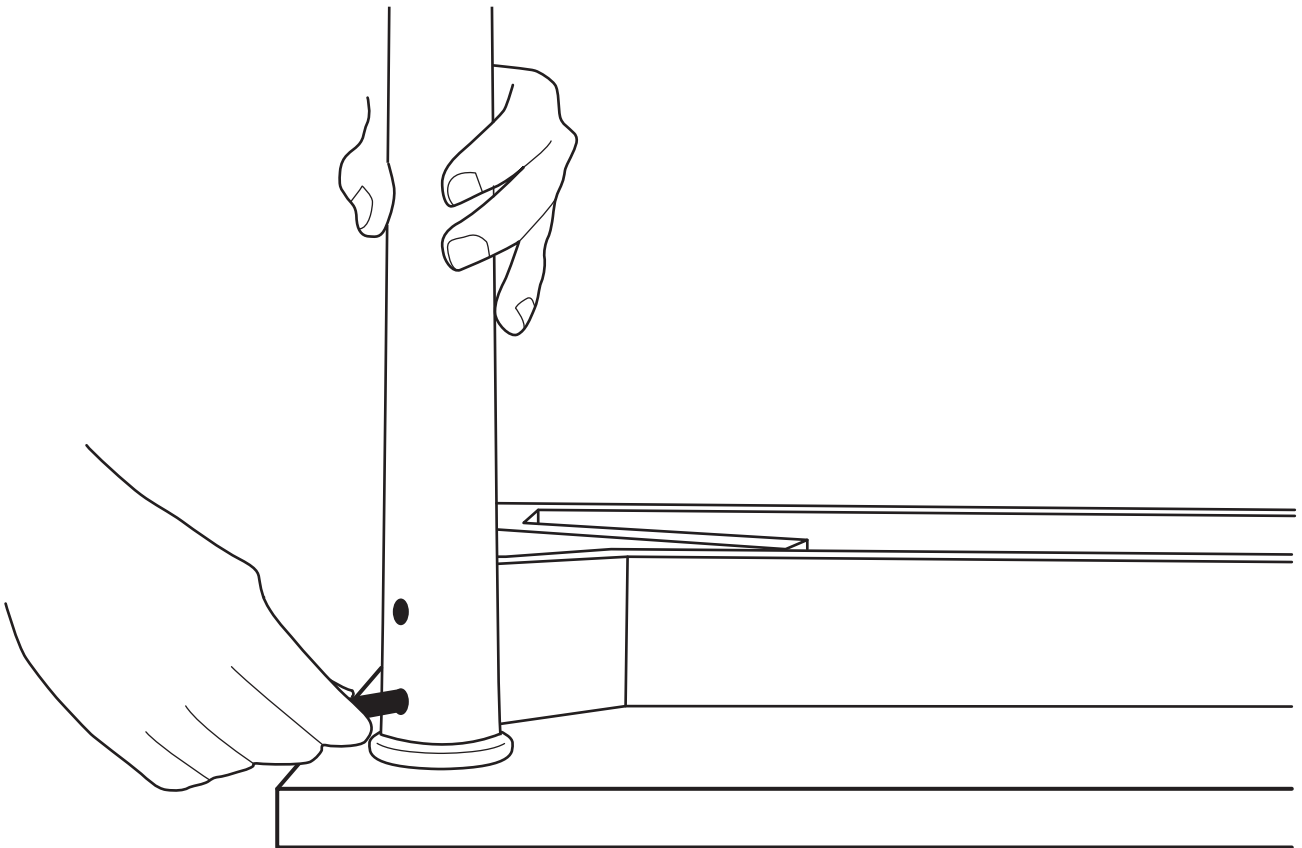

5

Check frame to ensure the locking mechanism is in the locked position.

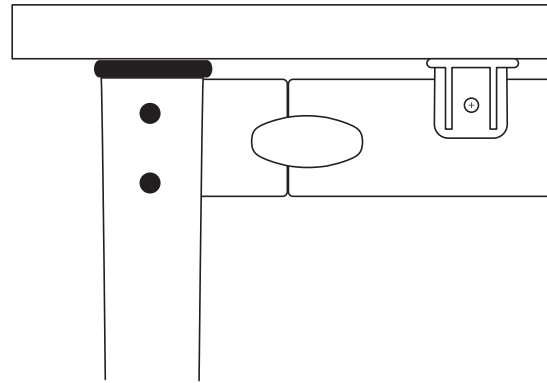

6

Two people should then flip over the completed table and place on the floor.

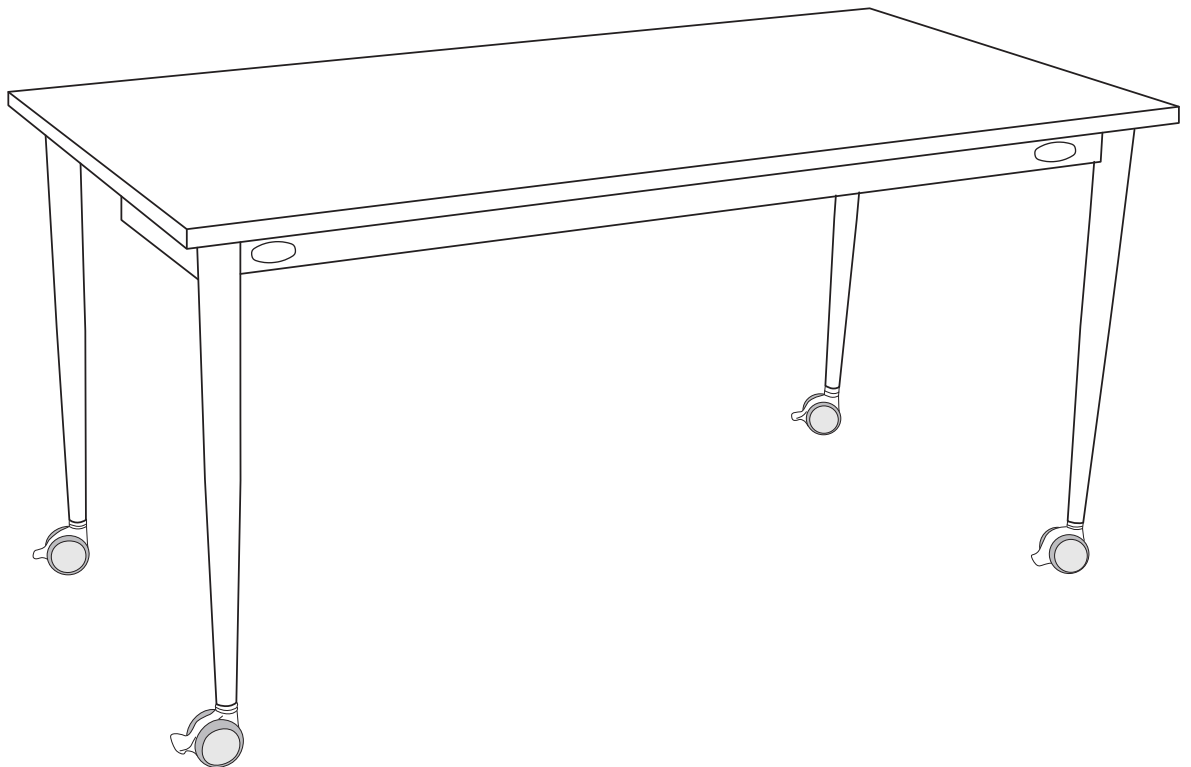

demco® imagine what's possible™

If you require assistance during assembly, our Customer Service team can help you!

Email custserv@demco.com or call 800.356.1200.